

BROME®

CATALOGUE 2024*









* Brome reserves the right to change prices from time to time and at its sole discretion.

- **SquirrelBuster®** Bird Feeders
- **RaccoonBuster® & BirdsUP™** Pole Systems
- **TUBE SOLUTION™ FAMILY** Bird Feeders

brome.com

TABLE OF CONTENTS

About Us	3	
Squirrel Busters	4 - 31	
Tube Solution Family	32 - 43	
Pole Systems	44 - 59	
Podium Series	60 - 71	
Accessories	72 - 79	
About Us	80 - 83	



ABOUT US

Brome Bird Care has been designing and manufacturing wild bird feeders since 1998. They are designed according to our Legacy Commitment and are recognized by customers and retailers to be top ranked wild bird feeders.

Our Lifetime Care™

Should you need a part covered under our warranty, we will provide it for free to extend the life of our products, and shipping is on us. Call us for advice or help. A real person will be happy to assist: 1-800-856-5685 Monday through Friday, from 9:00 AM to 5:30 PM (EST), except holidays.



Our Unilateral Policy

Our products are covered under our Unilateral Resale Pricing, Warranty and Internet Policy. Only authorized dealers are permitted to market our products.

Our Legacy Commitment



- **Legacy Construction™** : Disposable products are no longer an option. All of our products are designed with our planet in mind and based on our Legacy Construction™ design code. All parts are designed to be replaceable and recyclable. The future of new products, manufacturing and the preservation of our planet must be linked to a vision of products made to last.



- **Bird Conservation** : We proudly support bird conservation by donating our feeders to the Canadian Wildlife Federation and to over 25 bird festivals in North America to help them with their fundraising efforts. Each feeder's literature also includes links to Project FeederWatch, promoting birdwatching and research, as well as encouraging our customers to be part of a bigger movement for wildlife conservation.



- **Brome Bird News** : Our free online show is dedicated to birds and everyone who loves them. Buying a Brome® product is just the beginning of a rather exciting journey. Join us to learn more!

SquirrelBuster®



WILD BIRD FEEDER

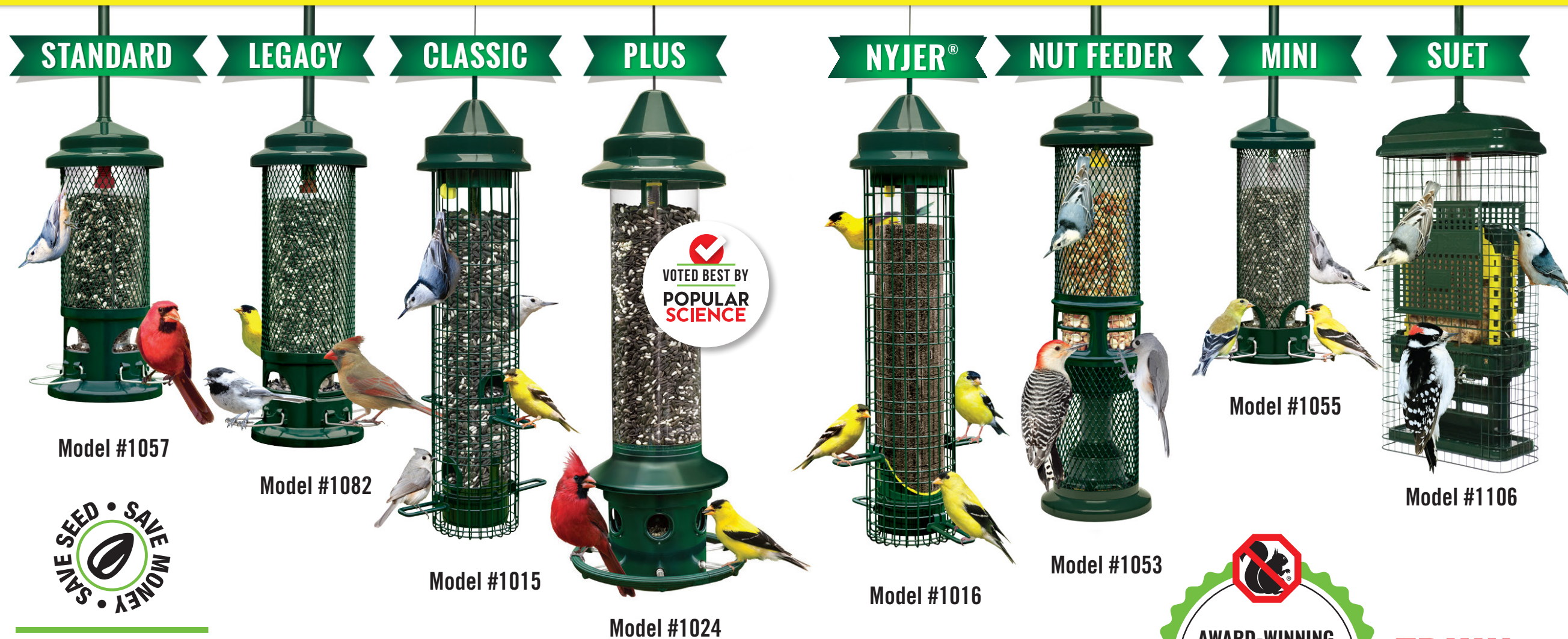

PAYS FOR ITSELF IN SAVED SEED®

VOTED BEST BY POPULAR SCIENCE



TRULY SQUIRREL-PROOF™

LIFETIME CARE™ 1-800-856-5685



TRULY
SQUIRREL-PROOF™



How it Works

Openings in the shroud align with the ports, providing birds access to the food. When a squirrel climbs onto the feeder, its weight automatically forces the shroud down, closing access to the ports. Squirrels and some large birds are foiled but not harmed in any way. See videos at www.brome.com



**WE WERE VOTED
BEST SQUIRREL-PROOF
BIRD FEEDER
BY POPULAR SCIENCE**



**VOTED BEST BY
POPULAR
SCIENCE**



**PATENT
PROTECTED**

We have 60 patents granted
plus 34 patents pending.



SEE VIDEO

SquirrelBuster®

PLUS

Retail
\$119.95

Model #1024-V01	Product & Box	Master Carton
Qty	1	2
Product Materials	Metal, Plastic & Resin	N/A
Capacity	3 quarts/5.1 lbs	N/A
Dimensions (W x L x H)	6.5" x 6.5" x 23.8"	13.8" x 7.0" x 24.38"
Weight	3.7 lbs.	8.4 lbs.
UPC	628209010240	10628209010247

BEST SELLER - LARGE SEED CAPACITY



-  **TRULY SQUIRREL-PROOF™**
-  **CHEW PROOF**
-  **DETACHABLE COMPONENT SYSTEM™**
-  **WEIGHT ADJUSTABLE**
-  **SEED TUBE VENTILATION™**
-  **UV RESISTANT**
-  **LIFETIME CARE™**

**VOTED BEST BY
POPULAR
SCIENCE**

Right Food
=
more bird traffic



BLACK OIL
SUNFLOWER



SAFFLOWER



MIXED SEEDS



DRIED
MEALWORMS



Accessories
available

Pole-mountable

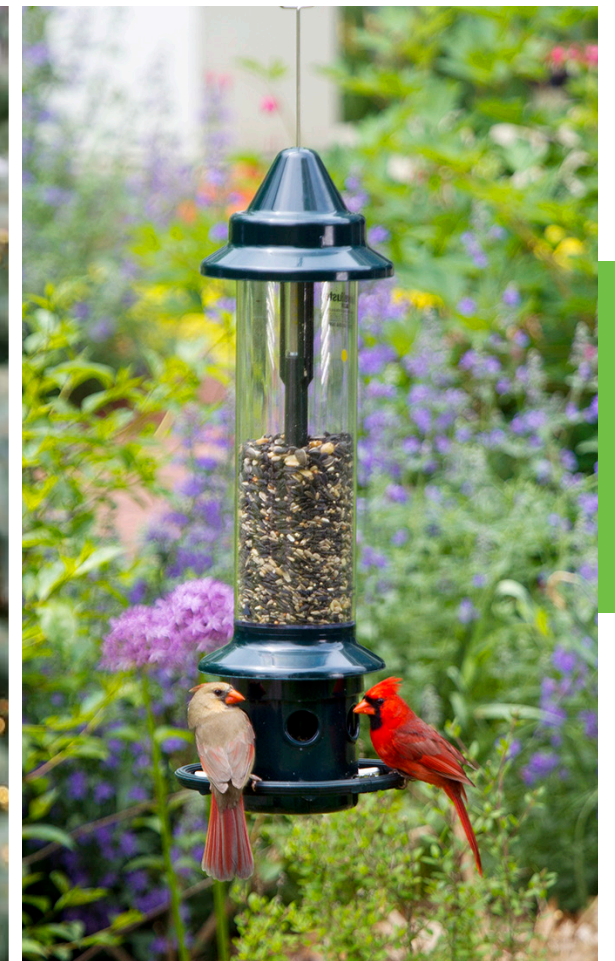

**CARDINAL
RING SYSTEM™**

Cardinals prefer to face their food source as they have difficulty turning their heads to feed. The custom grip profile of our patented Cardinal Ring System™ allows them to perch securely and feed comfortably.



SEE VIDEO

SquirrelBuster®

CLASSIC

Retail
\$72.95

Model #1015-V01	Product & Box	Master Carton
Qty	1	2
Product Materials	Metal & Plastic	N/A
Capacity	1.4 quarts/2.4 lbs	N/A
Dimensions (W x L x H)	5.3" x 5.3" x 20.63"	11.5" x 5.88" x 21.63"
Weight	2.7 lbs.	6 lbs.
UPC	628209010158	10628209010155

**A TIME-HONORED FEEDER
BIRDS CAN ALWAYS
COUNT ON**



TRULY SQUIRREL-PROOF™



CHEW PROOF



DETACHABLE
COMPONENT SYSTEM™



UV RESISTANT



SEED TUBE VENTILATION™



LIFETIME CARE™

Right Food
=
more bird traffic



BLACK OIL
SUNFLOWER



SAFFLOWER



MIXED SEEDS



DRIED
MEALWORMS



For both
clinging &
perching birds





SEE VIDEO

Squirrel Buster®

NYJER®

Model #1016-V01	Product & Box	Master Carton
Qty	1	2
Product Materials	Metal & Plastic	N/A
Capacity	1.4 quarts/2.4 lbs	N/A
Dimensions (W x L x H)	5.3" x 5.3" x 20.625"	5.875" x 11.5" x 21.625"
Weight	2.7 lbs.	6 lbs.
UPC	628209010165	10628209010162



WORTH ITS WEIGHT IN GOLD(FINCHES)!



TRULY SQUIRREL-PROOF™



CHEW PROOF



DETACHABLE
COMPONENT SYSTEM™



UV RESISTANT



SEED TUBE VENTILATION™



LIFETIME CARE™

Right Food
=
more bird traffic



NYJER® SEED
ONLY

Nyjer® is a registered trademark of the Wild Bird Feeding Institute.



8 feeding ports



For both
clinging &
perching birds





SEE VIDEO

SquirrelBuster®

MINI

Model #1055-V01	Product & Box	Master Carton
Qty	1	4
Product Materials	Metal & Plastic	N/A
Capacity	0.6 quarts/1 lb	
Dimensions (W x L x H)	4.13" x 4.13" x 12.38"	4.5" x 12.875" x 16.875"
Weight	1.45 lbs.	6.5 lbs.
UPC	628209010554	10628209010551



MINI BUT MIGHTY!



TRULY SQUIRREL-PROOF™



CHEW PROOF



DETACHABLE COMPONENT SYSTEM™



UV RESISTANT



SEED TUBE VENTILATION™



LIFETIME CARE™

Right Food
=
more bird traffic



BLACK OIL SUNFLOWER



SAFFLOWER



MIXED SEEDS



DRIED MEALWORMS



For both clinging & perching birds





SEE VIDEO

SquirrelBuster®

STANDARD

Retail
\$49.95

Model #1057-V01	Product & Box	Master Carton
Qty	1	4
Product Materials	Metal, Plastic & Resin	N/A
Capacity	3/4 quarts/1.3 lbs	N/A
Dimensions (W x L x H)	5" x 5" x 13.25"	20.88" x 13.88" x 5.63"
Weight	2 lbs.	9.5 lbs.
UPC	628209010578	10628209010575

COMPACT DESIGN FOR TAILORED BIRD FEEDING



TRULY SQUIRREL-PROOF™



CHEW PROOF



DETACHABLE COMPONENT SYSTEM™



WEIGHT ADJUSTABLE



SEED TUBE VENTILATION™



UV RESISTANT



LIFETIME CARE™

Right Food
=
more bird traffic



BLACK OIL SUNFLOWER



SAFFLOWER



MIXED SEEDS



DRIED MEALWORMS

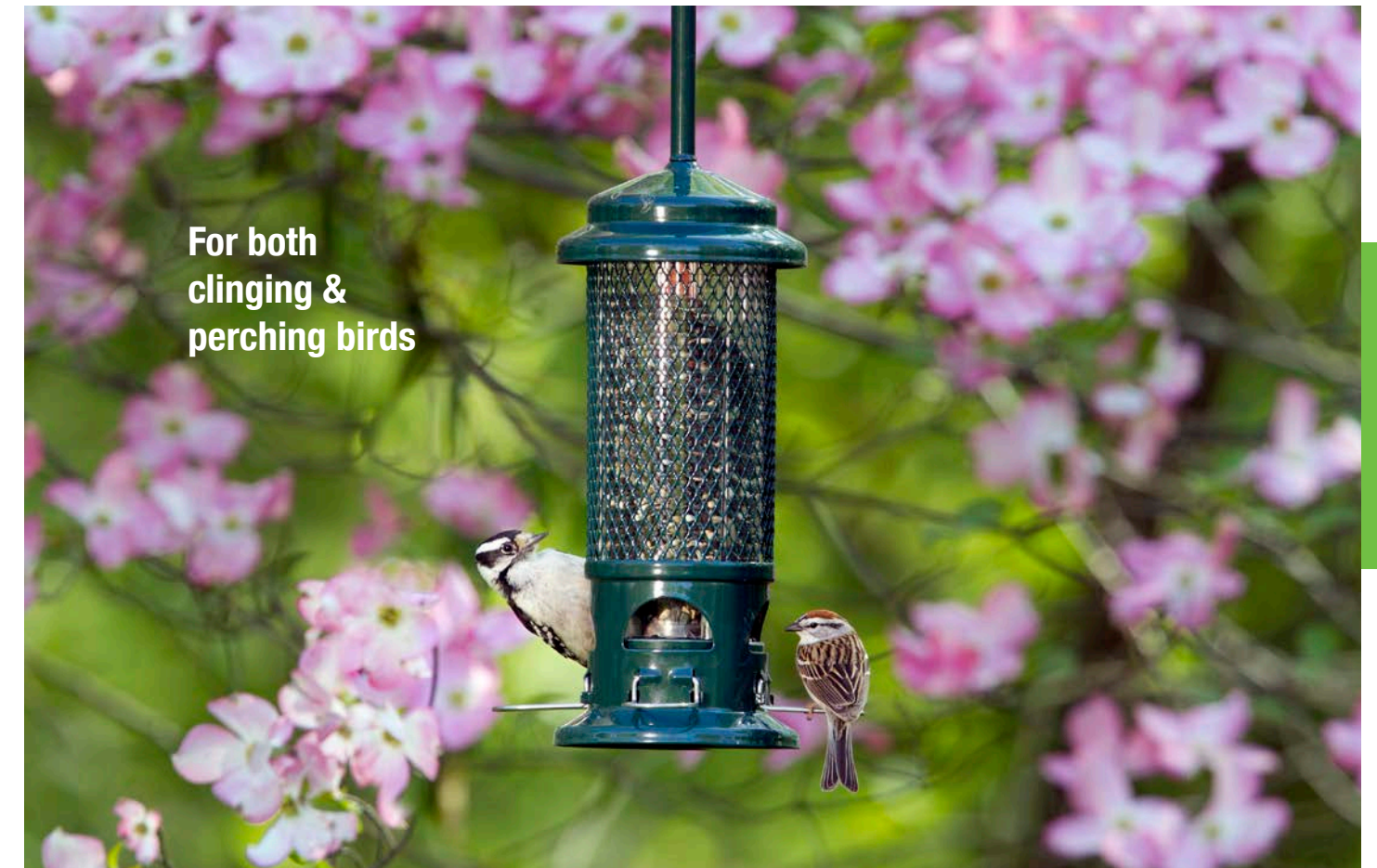

For both clinging & perching birds





SEE VIDEO

SquirrelBuster®

LEGACY

Retail
\$68.95

Model #1082-V01	Product & Box	Master Carton
Qty	1	2
Product Materials	Metal, Plastic & Resin	N/A
Capacity	1.5 quarts/2.6 lbs	
Dimensions (W x L x H)	5.5" x 5.5" x 16"	11.50" x 6.0" x 16.75"
Weight	2.7 lbs.	6.6 lbs.
UPC	628209010820	10628209010827



LARGE SEED CAPACITY!



TRULY SQUIRREL-PROOF™



CHEW PROOF



DETACHABLE COMPONENT SYSTEM™



WEIGHT ADJUSTABLE



SEED TUBE VENTILATION™



UV RESISTANT



LIFETIME CARE™

Right Food
=
more bird traffic



BLACK OIL SUNFLOWER



SAFFLOWER



MIXED SEEDS



DRIED MEALWORMS

For both
clinging &
perching birds





SEE VIDEO

SquirrelBuster®

NUT FEEDER

Retail
\$86.95

Model #1053-V01	Product & Box	Master Carton
Qty	1	2
Product Materials	Metal, Plastic & Resin	N/A
Capacity	3/4 quarts/1.3 lbs	N/A
Dimensions (W x L x H)	5.13" x 5.13" x 19.38"	10.88" x 5.63" x 20.38"
Weight	2.6 lbs.	6 lbs.
UPC	628209105311	10628209105318

**A FIRST-EVER
INTERCHANGEABLE
MESH FEEDER**



A HIGH-ENERGY FEEDER BIRDS CANNOT RESIST

Right Food
=
more bird traffic



TRULY SQUIRREL-PROOF™



NO MESS NO WASTE®



DETACHABLE
COMPONENT SYSTEM™



WEIGHT ADJUSTABLE



WOODPECKER-SAFE



UV RESISTANT



CREATIVE BIRD FEEDING



LIFETIME CARE™



RED-SKINNED
SHELLED PEANUTS



SHELLED
PEANUTS



CASHEWS



NUT AND FRUIT MIX



PECANS



DRIED FRUIT



SUET NUGGETS



ALMONDS



WOODPECKER FRIENDLY TAIL PROP





SEE VIDEO

SquirrelBuster®

SUET

Retail
\$98.95

Model #1106-V01	Product & Box	Master Carton
Qty	1	2
Product Materials	Metal & Plastic	N/A
Capacity	2 suet cakes 4.5" x 4.5" x 1"	N/A
Dimensions (W x L x H)	8 5/8" x 4 1/2" x 18 5/8"	9 1/2" x 10" x 19 1/2"
Weight	3.7 lbs.	8.4 lbs.
UPC	628209110612	10628209110619

INNOVATIVE DESIGN FOR YOUR SUET-LOVING BIRDS



TRULY SQUIRREL-PROOF™



CHEW PROOF



DETACHABLE COMPONENT SYSTEM™



WEIGHT ADJUSTABLE



GREASE-FREE HANDLING



UV RESISTANT



LIFETIME CARE™



CRUMB PORT

Right Food
=
more bird traffic



HOLDS 2 SUET CAKES
4.5 IN X 4.5 IN X 1 IN

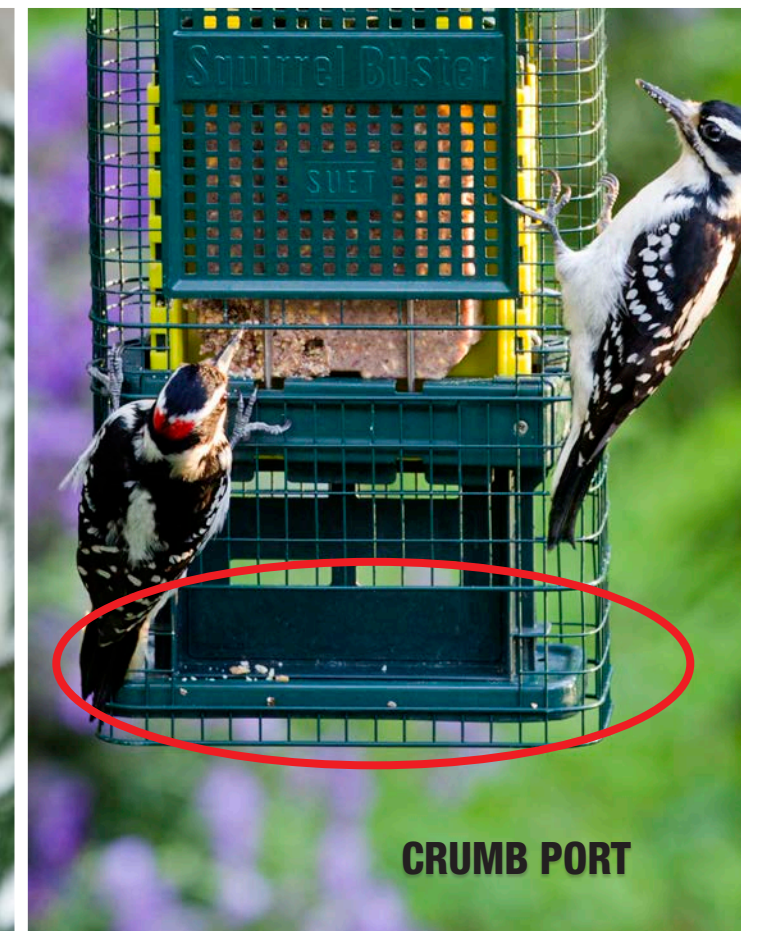
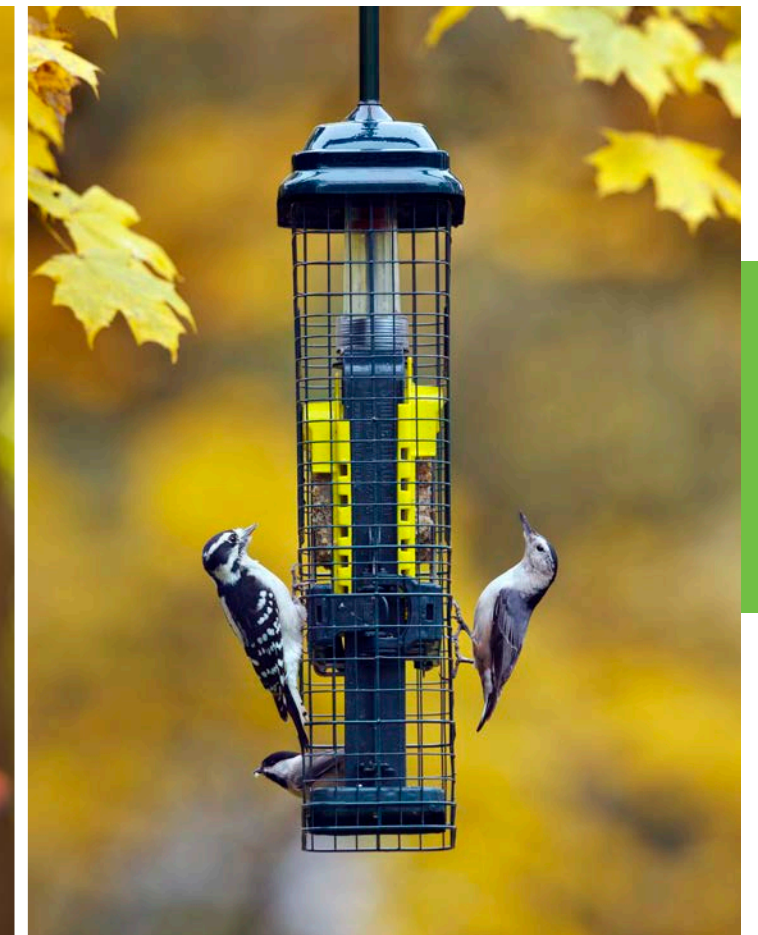

CRUMB PORT

Squirrel Buster®

ACCESSORIES



#1026-V01

Weather Guard for the Squirrel Buster® Plus

- Give your birds shelter
- Polycarbonate weather guard
- UV protected
- Weather proof



#1025-V01

Pole Adaptor for the Squirrel Buster® Plus

- Fits a 1-inch pole (outside diameter)
- Powder coated die cast pole adaptor
- Stainless steel mid ring to thwart squirrels
- Guaranteed 100% squirrel proof and rust proof



#1020-V01

Seed Buster®

Tray Feeder and Seed Catcher

- Increases wild bird traffic
- Large tray feeder
- Large seed catcher
- Eliminates the ground mess
- Fits a 1-inch pole (outside diameter)

LIFETIME CARE™ 1-800-856-5685

Squirrel Buster®



Weather Guard

Model #1026-V01	Product & Box	Master Carton
Qty	1	4
Product Materials	Plastic	N/A
Dimensions (W x L x H)	2" x 13.25" x 13.25"	14.0" x 14.0" x 9.5"
Weight	0.9 lbs.	4.4 lbs
UPC	628209010264	10628209010261

GIVE BIRDS SHELTER!

For Squirrel Buster® Plus, model 1024 only



- 
 DETACHABLE
 COMPONENT SYSTEM™
- 
 UV RESISTANT
- 
 LIFETIME CARE™



Squirrel Buster®

Pole Adaptor

Model #1025-V01	Product & Box	Master Carton
Qty	1	4
Product Materials	Metal	N/A
Dimensions (W x L x H)	3" x 9" x 11"	9.75" x 11" x 11.625"
Weight	0.75 lbs.	4 lbs.
UPC	628209010257	10628209010254

Only fits the Squirrel Buster® Plus, model 1024 feeder and the 1-inch Single Pole Kit, model 1108



CHEW PROOF



DETACHABLE COMPONENT SYSTEM™



UV RESISTANT



LIFETIME CARE™

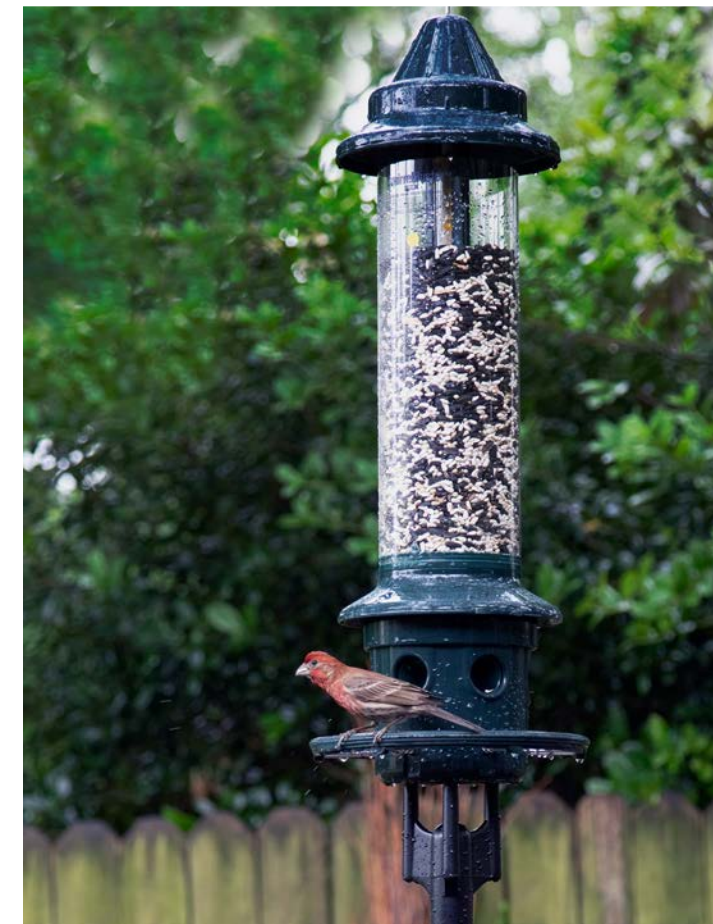

Seed Buster®

Seed Catcher Tray

Model #1020-V01	Product & Box	Master Carton
Qty	1	2
Product Materials	Plastic & resin	N/A
Dimensions (W x L x H)	4" x 11" x 21"	8.5" x 11.5" x 21.5"
Weight	3 lbs.	7 lbs.
UPC	628209102013	10628209102010

CATCHES DROPPED SEED TO FEED MORE BIRDS!

Fits 1-inch (outside diameter) Pole

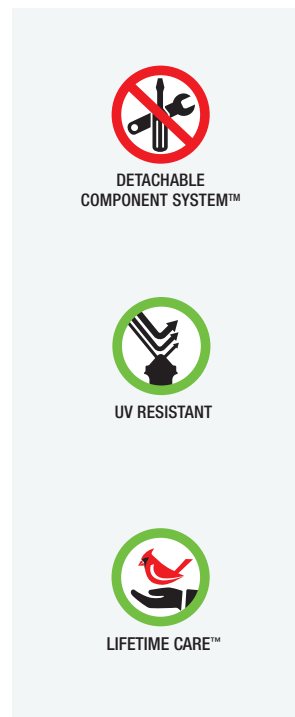

TUBE SOLUTION™ FAMILY

FEATURES

- 1 Detachable Cover with Rotating Hanger.
- 2 PosiGrip Perch™ that no birds can resist!
- 3 Extra Large, Heavy Duty, UV Resistant, Polycarbonate Tube.
- 4 Easy-off Ports.
- 5 Optional Seed Tray.
- 6 Easy-off Base.
- 7 Integrated Pole Mounting.



CHEW PROOF



NO TOOLS



SEED TUBE VENTILATION™



UV RESISTANT

LIFETIME CARE™ 1-800-856-5685

TUBE SOLUTION™ FAMILY

WILD BIRD FEEDER

There are 3 sizes of Tube Solutions™ for you to choose from.

TUBE SOLUTION™ 100



1.7 lbs

MODEL #1115-V01

TUBE SOLUTION™ 150



2.6 lbs

MODEL #1116-V01

TUBE SOLUTION™ 200



3.4 lbs

MODEL #1117-V01

SEED TRAY ACCESSORY AVAILABLE

Stop all the wasted food and mess on the ground with our easy-to-install tray accessory for the Tube Solution™. It has drainage holes with a slope design to move seeds to the outside. There is also a wide perching outer rim to allow more birds to fit without interfering with each other. A perfect addition to increase bird traffic.



MODEL #3003-V01



CHEW PROOF



NO TOOLS



SEED TUBE VENTILATION™



UV RESISTANT

LIFETIME CARE™ 1-800-856-5685



SEE VIDEO

TUBE SOLUTION™ 100

Model #1115-V01	Product & Box	Master Carton
Qty	1	6
Product Materials	Metal & Plastic	N/A
Capacity	1 quarts / 1.7 lbs	N/A
Dimensions (W x L x H)	7.25" x 4.625" x 12"	12" x 18" x 14"
Weight	1 lbs.	9 lbs.
UPC	628209111510	10628209111517



QUALITY TUBE FEEDER WITH ULTRA-COMFORT PERCHES

2 perches



DETACHABLE COMPONENT SYSTEM™



CHEW PROOF



SEED TUBE VENTILATION™



UV RESISTANT



LIFETIME CARE™



POLE MOUNTABLE

Right Food = more bird traffic



BLACK OIL SUNFLOWER



SAFFLOWER



MIXED SEEDS



DRIED MEALWORMS





SEE VIDEO

TUBE SOLUTION™ 150

Model #1116-V01	Product & Box	Master Carton
Qty	1	6
Product Materials	Metal & Plastic	N/A
Capacity	1.5 quarts/2.6 lbs	N/A
Dimensions (W x L x H)	5.5" x 5.5" x 15.8"	12" x 18" x 17"
Weight	1.4 lbs.	10 lbs.
UPC	628209111619	10628209111616



QUALITY TUBE FEEDER WITH ULTRA-COMFORT PERCHES

4 perches

Right Food = more bird traffic

 DETACHABLE COMPONENT SYSTEM™	 CHEW PROOF
 SEED TUBE VENTILATION™	 UV RESISTANT
 LIFETIME CARE™	 POLE MOUNTABLE



BLACK OIL SUNFLOWER



SAFFLOWER



MIXED SEEDS



DRIED MEALWORMS





SEE VIDEO

TUBE SOLUTION™ 200

Model #1117-V01	Product & Box	Master Carton
Qty	1	6
Product Materials	Metal & Plastic	N/A
Capacity	2 quarts/3.4 lbs	N/A
Dimensions (W x L x H)	5.5" x 5.5" x 19.7"	12" x 18" x 21"
Weight	1.6 lbs.	12 lbs.
UPC	628209111718	10628209111715



QUALITY TUBE FEEDER WITH ULTRA-COMFORT PERCHES

6 perches



DETACHABLE COMPONENT SYSTEM™



CHEW PROOF



SEED TUBE VENTILATION™



UV RESISTANT



LIFETIME CARE™



POLE MOUNTABLE

Right Food
=
more bird traffic



BLACK OIL SUNFLOWER



SAFFLOWER



MIXED SEEDS



DRIED MEALWORMS





SEE VIDEO

SEED TRAY ACCESSORY

Model #3003-V01	Product & Box	Master Carton
Qty	1	6
Product Materials	Polycarbonate Resin	N/A
Capacity	N/A	N/A
Dimensions (W x L x H)	10.9" x 10.9" x 1.13"	13" x 13" x 9"
Weight	0.4 lbs.	4 lbs.
UPC	628209300310	10628209300317



Fits Tube Solution 100, 150 and 200



DETACHABLE
COMPONENT SYSTEM™



UV RESISTANT



LIFETIME CARE™





SEE VIDEO

BirdsUP™

Retail
\$69.95

1 INCH SINGLE POLE KIT

Model #1108-V01	Product & Box	Master Carton
Qty	1	6
Product Materials	Metal	N/A
Capacity	N/A	N/A
Dimensions (W x L x H)	1.6" x 4.8" x 21.3"	21.9" x 5.4" x 10.2"
Weight	9 lbs.	55 lbs.
UPC	628209110810	10628209110817

A MULTITUDE OF USES!



EASY SET-UP
5 MINUTES

Installed height: 60 in
Pole diameter: 1 in

Patented Quadra Cut Screw™



Reduces friction
Increases hold

NO TOOLS CEMENT DIGGING

Included:

- 1 Bullseye level
- 3 Pole sections
- 1 Ground screw
- 1 Wedge
- 1 Torque bar
- 1 Lubricant pouch

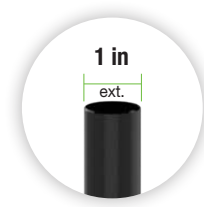

1 in
ext.
Pole diameter

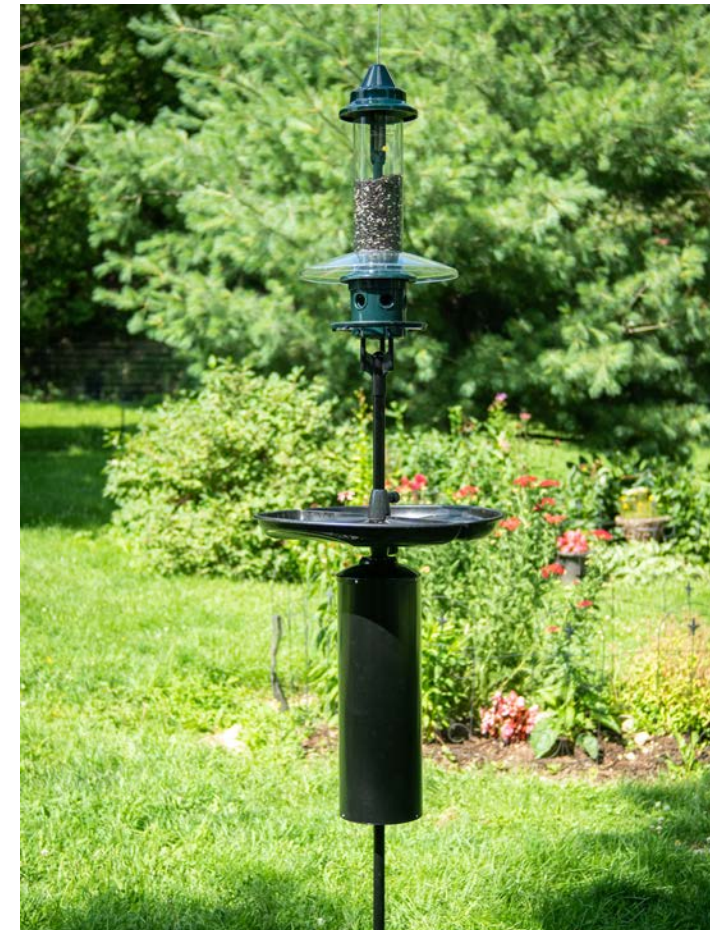

1 INCH SINGLE POLE KIT

CREATE YOUR OWN BIRD SANCTUARY

- Use this pole to attach bird feeders, nest boxes, seed trays, bird baths and protect them with a Raccoon Buster® Baffle.

1 - BirdsUP™ Detachable Seed Tray

2 - Hopper Bird Feeder

3 - Nest Box

4 - Raccoon Buster® Baffle

5 - BirdsUP™ Mounting Flange

6 - Squirrel Buster® Plus

7 - Squirrel Buster® Pole Adaptor

8 - Tube Feeder

Accessories not included





SEE VIDEO

BirdsUP™

Retail
\$156.95

1 INCH VERSA™ POLE SYSTEM

PERFECT FOR ALL FEEDERS!

Model #1213-V01	Product & Box	Master Carton
Qty	1	4
Product Materials	Metal	N/A
Capacity	N/A	N/A
Dimensions (W x L x H)	4.6" x 4.1" x 41.3"	9.8" x 8.8" x 41.6"
Weight	10 lbs.	41 lbs.
UPC	628209121311	10628209121318

**NO TOOLS
CEMENT
DIGGING**



Installed height: 7.7 ft
Pole diameter: 1 in
Arm length: 21 in

**Patented Quadra
Cut Screw™**



**Reduces friction
Increases hold**

Included:

- 1 Finial with Bullseye level
- 4 Arms
- 1 Hub
- 2 Pole sections
- 1 Ground screw
- 1 Wedge
- 1 Torque bar
- 2 Stainless steel pins
- 1 Lubricant pouch

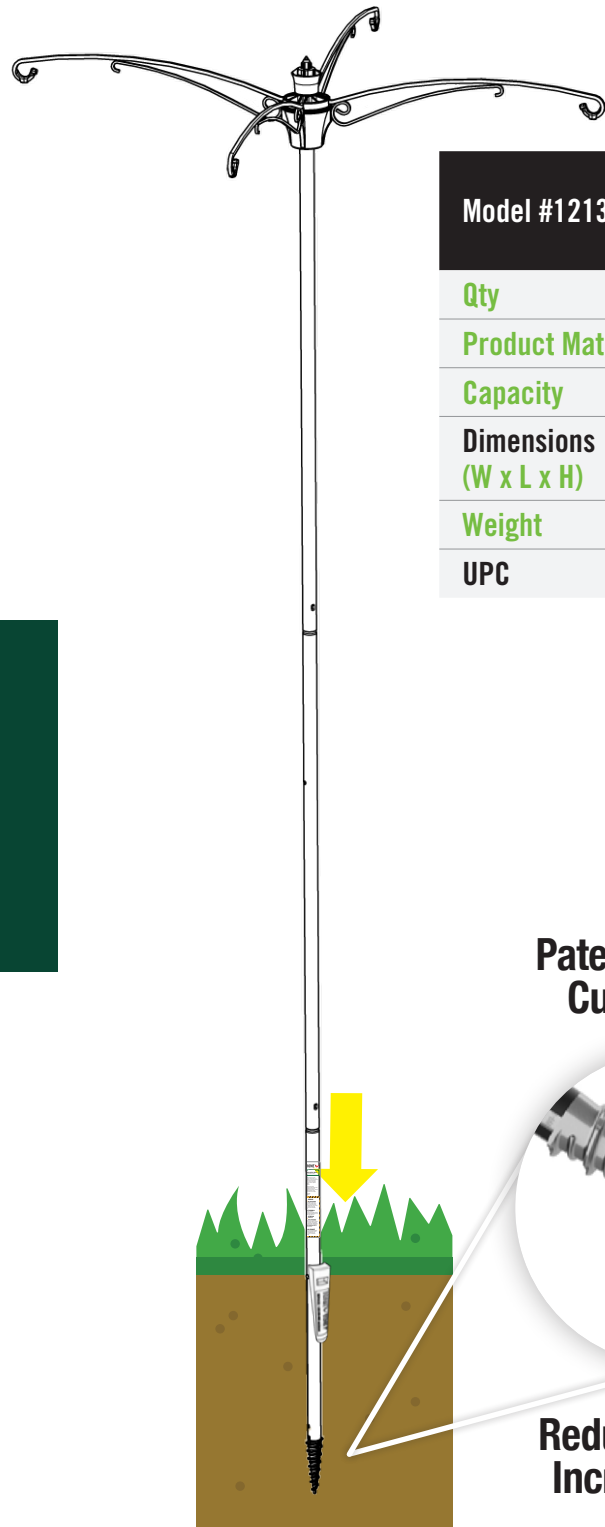
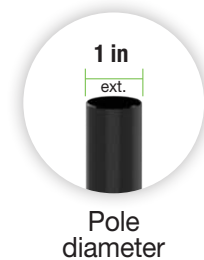



SEE VIDEO

Raccoon Buster®

Retail
\$329.95

1.5 INCH GUARDIAN POLE SYSTEM

PROBLEM SOLVED!

**HEAVY
DUTY**

Model #1143-V01	Product & Box	Master Carton
Qty	1	2
Product Materials	Metal	N/A
Capacity	N/A	N/A
Dimensions (W x L x H)	7.25" x 7.25" x 43.3"	15" x 7.6" x 43.7"
Weight	23 lbs.	47 lbs.
UPC	628209114313	10628209114310

**NO TOOLS
CEMENT
DIGGING**

**EASY
SET-UP
10 MINUTES**

Installed height: 8 ft
Pole diameter: 1.5 in
Baffle diameter: 7 in
Arm length: 25 in

**Patented Quadra
Cut Screw™**

**Reduces friction
Increases hold**

Included:

- 1 Finial with Bullseye level
- 4 Arms
- 1 Hub
- 2 Pole sections
- 1 Ground screw
- 1 Wedge
- 1 Torque bar
- 2 Stainless steel pins
- 1 Baffle
- 1 Lubricant pouch

1.5 in
ext.
Pole
diameter



FLOWER TREE

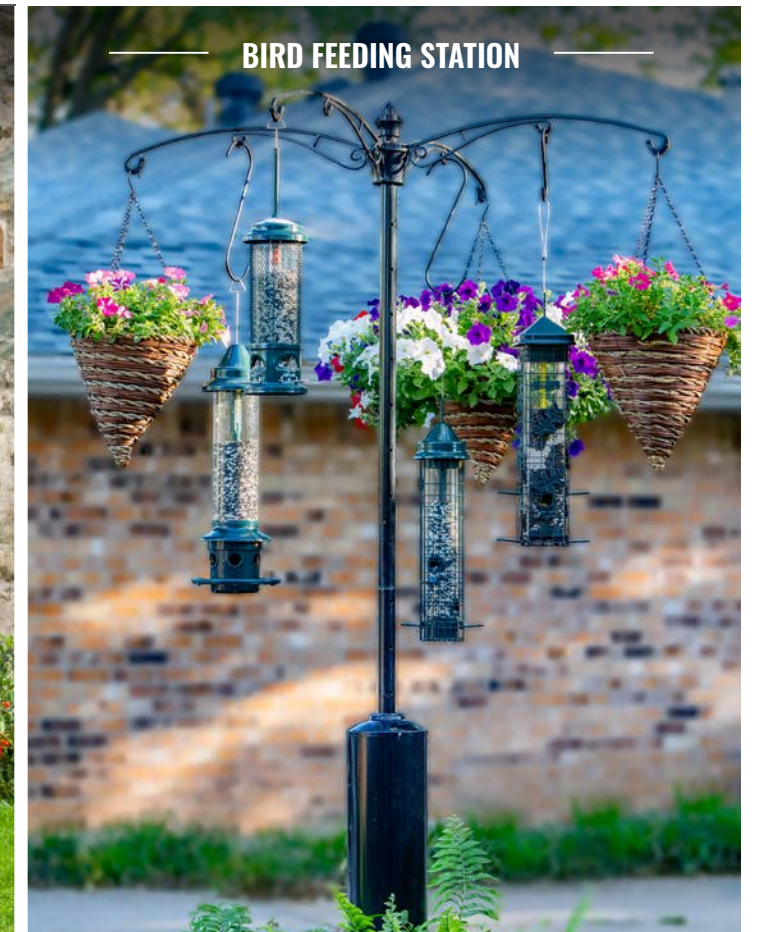

BIRD FEEDING STATION



VERTICAL GARDEN



HUMMINGBIRD STATION

Raccoon Buster®

1.5 INCH GUARDIAN POLE SYSTEM

ACCESSORIES (Sold separately)

Arm Kit
Model #1161-V01

Tray Kit
includes 2 seed trays
& 2 bird baths
Model #1158-V01

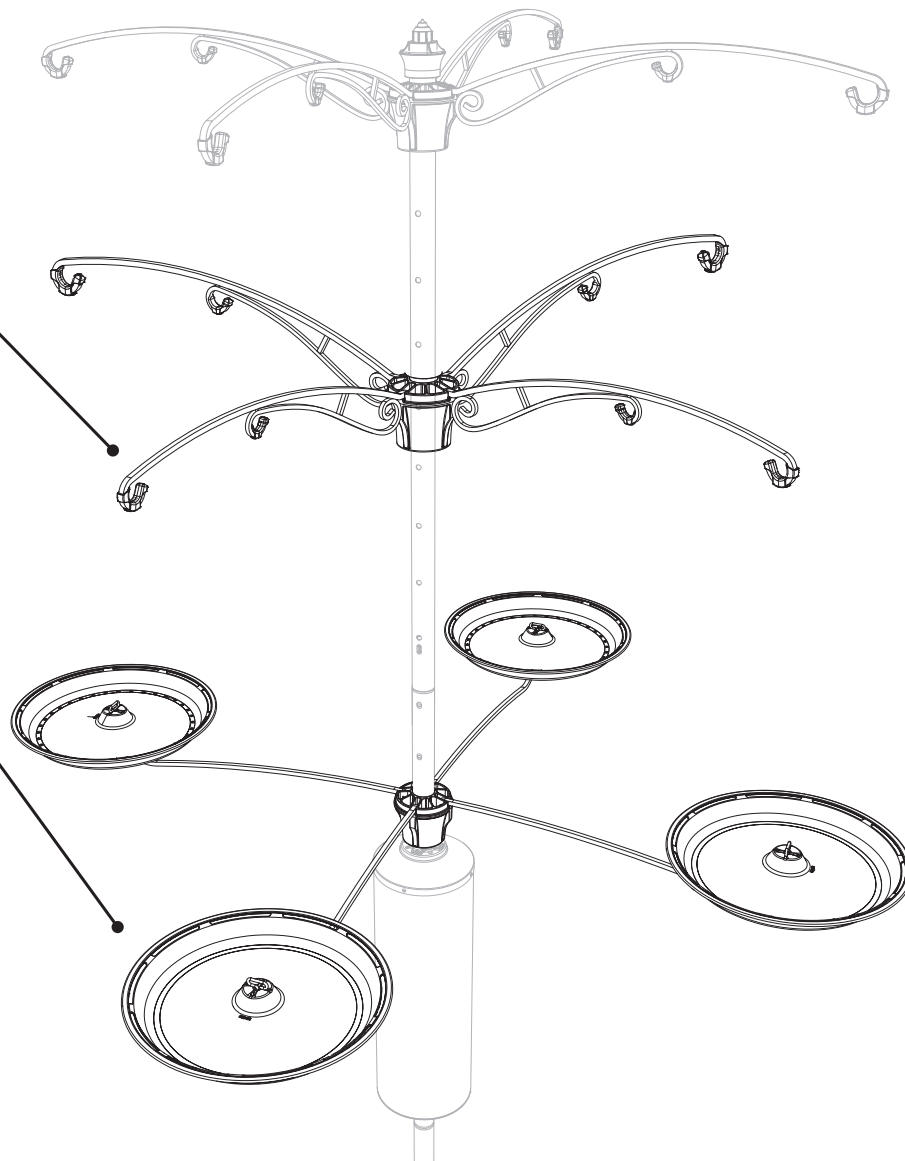



SEE VIDEO

RaccoonBuster®

ARM KIT

Model #1161-V01	Product & Box	Master Carton
Qty	1	2
Product Materials	Metal	N/A
Capacity	N/A	N/A
Dimensions (W x L x H)	4.6" x 4" x 29.8"	5" x 8.5" x 29.8"
Weight	6 lbs.	13 lbs.
UPC	628209116119	10628209116116

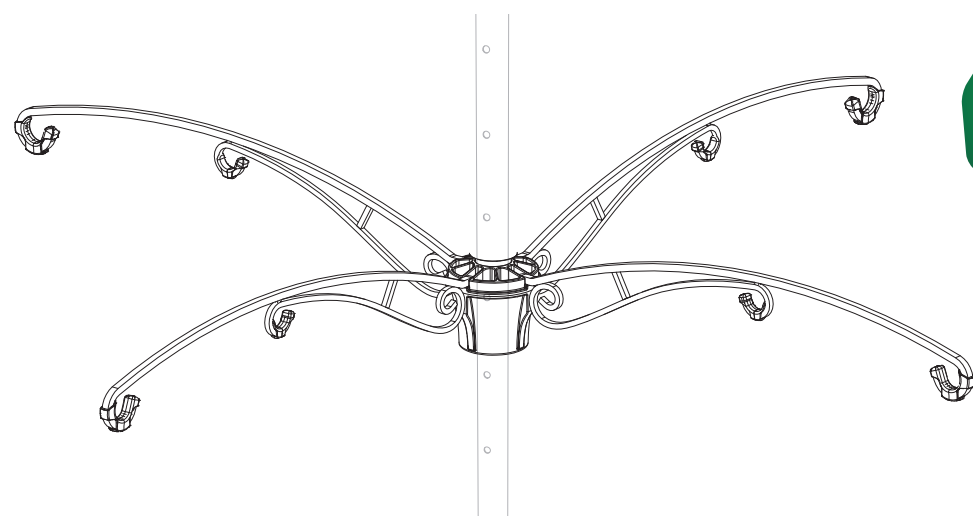

Included:

- 1 Hub
- 4 Arms
- 1 Stainless steel pin





SEE VIDEO

Raccoon Buster®

TRAY KIT

Model #1158-V01	Product & Box	Master Carton
Qty	1	2
Product Materials	Metal & Resin	N/A
Capacity	N/A	N/A
Dimensions (W x L x H)	15.3" x 24.8" x 4.0"	15.9" x 8.6" x 25.4"
Weight	7.4 lbs.	15 lbs.
UPC	628209115815	10629209115812

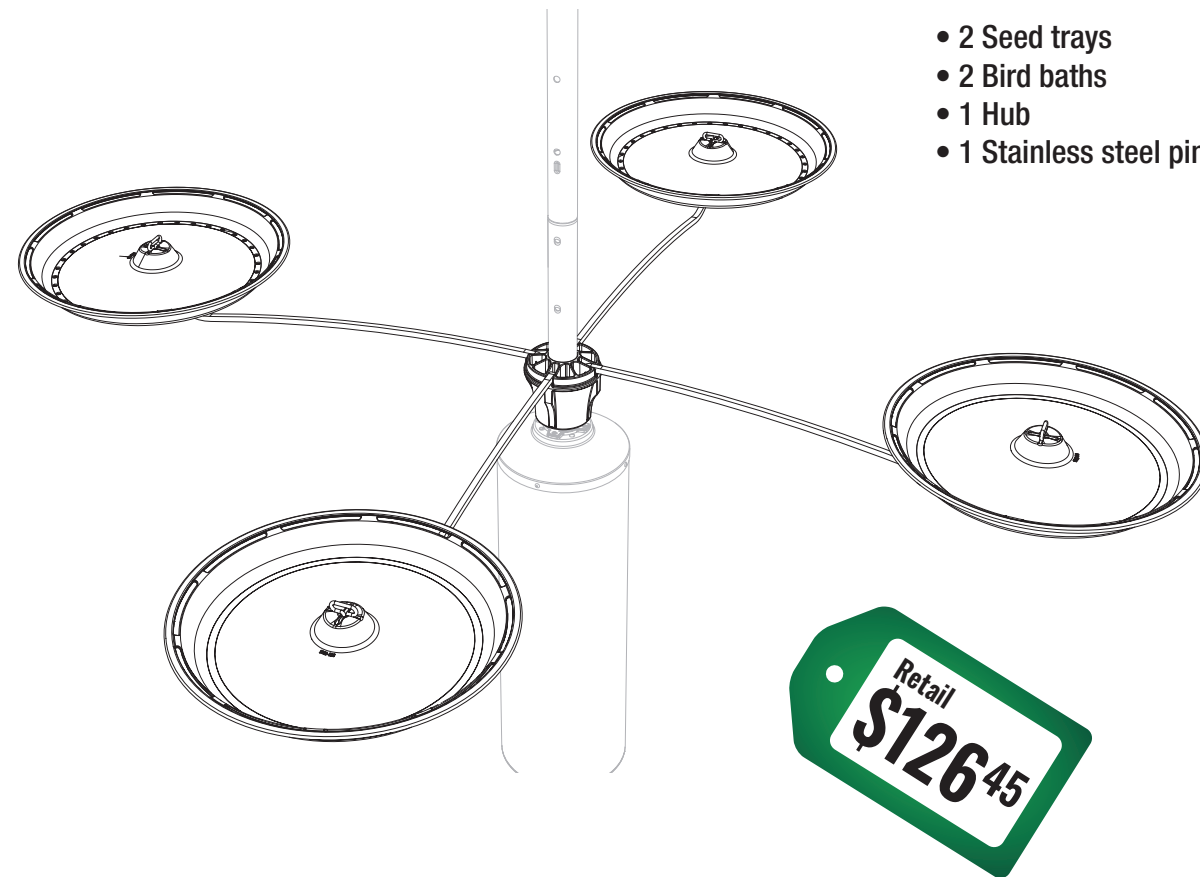

Included:

- 2 Seed trays
- 2 Bird baths
- 1 Hub
- 1 Stainless steel pin





SEE VIDEO

Raccoon Buster®

BAFFLE

Model #1151-V01	Product & Box	Master Carton
Qty	1	2
Product Materials	Metal	N/A
Capacity	N/A	N/A
Dimensions (W x L x H)	7.5" x 7.5" x 23.6"	7.6" x 15.1" x 24.1"
Weight	4.5 lbs.	10 lbs.
UPC	628209115112	10628209115119

PROBLEM SOLVED!

Fits Brome® 1 in and 1.5 in diameter poles

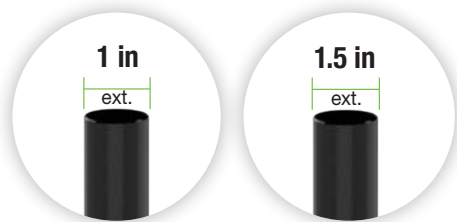

TRULY
RACCOON-PROOF™



Included:

- 1 Baffle
- 1 Stainless steel pin for 1.5 in pole
- 1 Stainless steel pin for 1 in pole

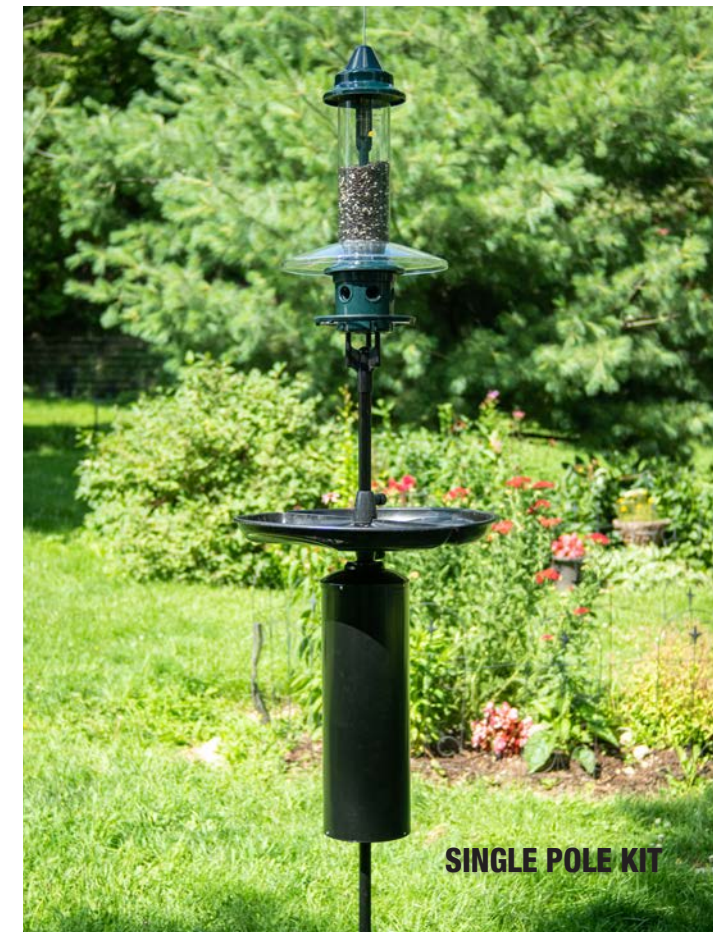



Podium™ series

THE ULTIMATE BIRD FEEDING STATION

SAVE 10%
by getting everything in
ONE convenient **PACKAGE!**
Feeder, pole and tray **ALL** in **ONE!**

NO TOOLS
CEMENT
DIGGING

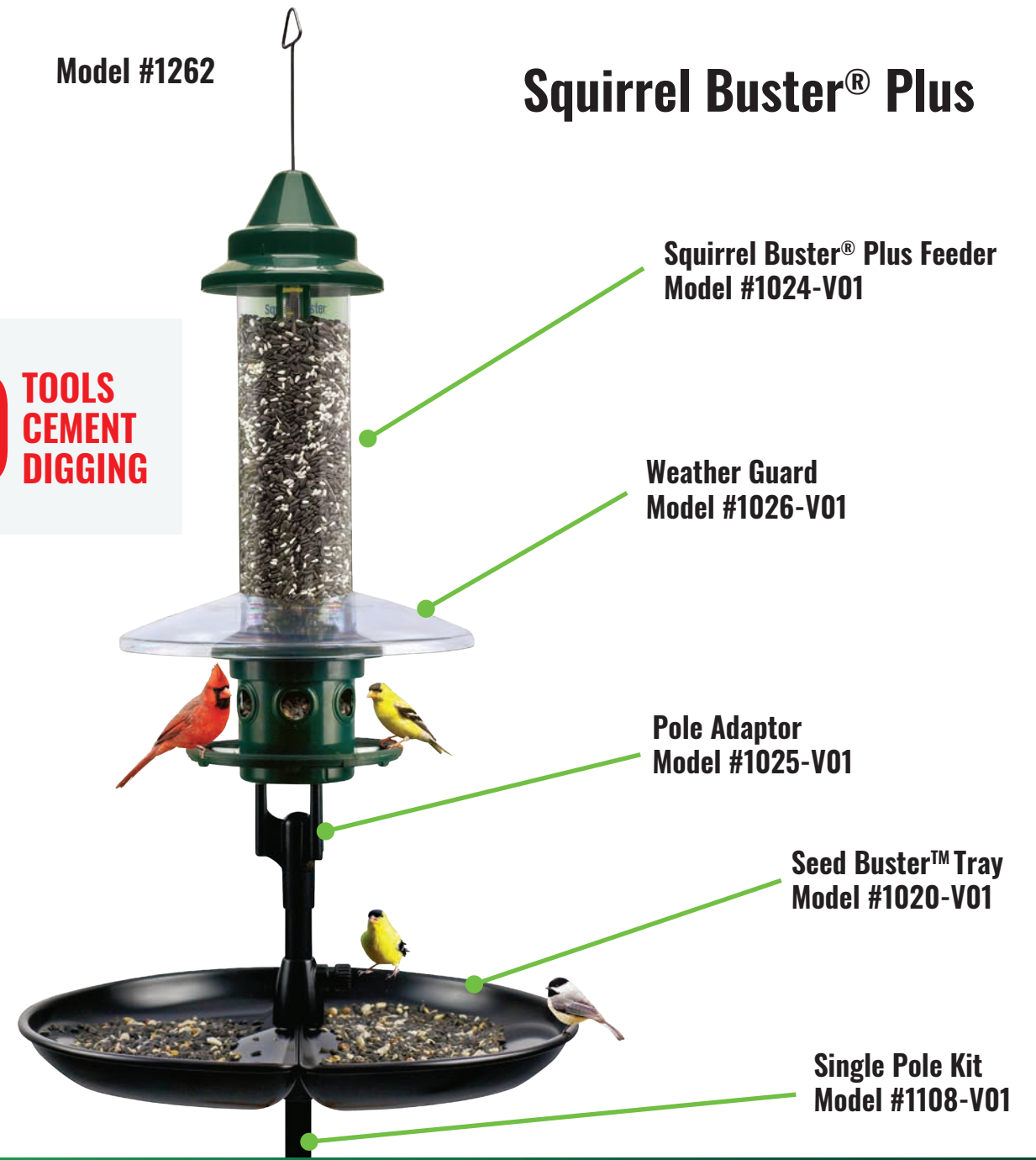

Easy Setup

Place Anywhere in Your Yard!

Squirrel Buster® Plus Podium™

1262

Included

- Single Pole Kit model #1108-V01
- Seed Buster™ Tray model #1020-V01
- Squirrel Buster® Plus Feeder model #1024-V01
- Weather Guard model #1026-V01
- Pole Adaptor model #1025-V01



SEE VIDEO

**THE ULTIMATE
SQUIRREL-PROOF
BIRD FEEDING
STATION!**



Model #1262-V01	Product & Box
Qty	1
Product Materials	Metal, Plastic & Resin
Capacity	3 quarts/5.1 lbs
Dimensions (W x L x H)	24" x 20" x 7"
Weight	14 lbs.
UPC	628209126217

Retail
\$259.95



DETACHABLE
COMPONENT SYSTEM™



TRULY SQUIRREL-PROOF™



CHEW PROOF



LIFETIME CARE™



WEIGHT ADJUSTABLE



SEED TUBE VENTILATION™



UV RESISTANT



VOTED BEST BY
**POPULAR
SCIENCE**



AWARD-WINNING
— PATENTED —
SQUIRRELPROOFING
TECHNOLOGY



**PAYS
FOR ITSELF
IN SAVED SEED®**



Mega600™ Podium™

1263

Included

- Single Pole Kit model #1108-V01
- Seed Buster™ Tray model #1020-V01
- Mega600™ Feeder model #1114-V01



SEE VIDEO

Model #1263-V01	Product & Box
Qty	1
Product Materials	Metal, Plastic & Resin
Capacity	3 quarts/5.1 lbs
Dimensions (W x L x H)	24" x 20" x 7"
Weight	11 lbs.
UPC	628209126316



THE ULTIMATE BIRD FEEDING STATION!

DETACHABLE COMPONENT SYSTEM™

CHEW PROOF

LIFETIME CARE™

SEED TUBE VENTILATION™

UV RESISTANT

PAYS FOR ITSELF IN SAVED SEED®

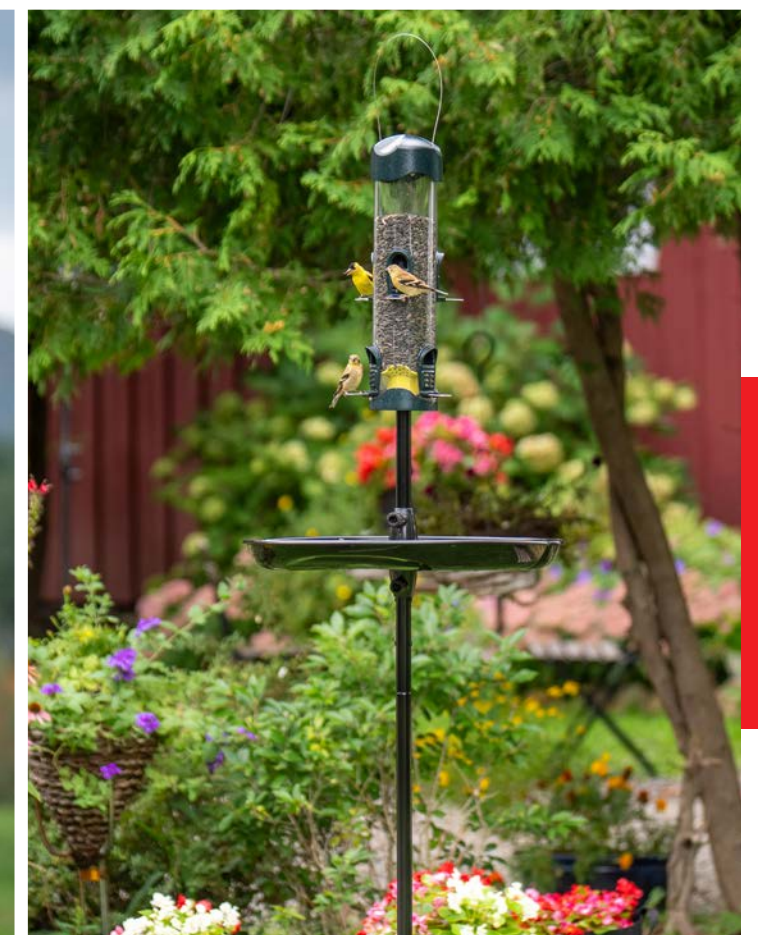

Tube Solution™ 100 Podium™

1267

Included

- Single Pole Kit model #1108-V01
- Seed Tray model #3003-V01
- Tube Solution™ 100 Feeder model #1115-V01



SEE VIDEO

**THE ULTIMATE BIRD
FEEDING STATION!**

Model #1267-V01	Product & Box
Qty	1
Product Materials	Metal & Plastic
Capacity	1 quarts / 1.7 lbs
Dimensions (W x L x H)	24" x 11.5" x 8.5"
Weight	9 lbs.
UPC	628209126712

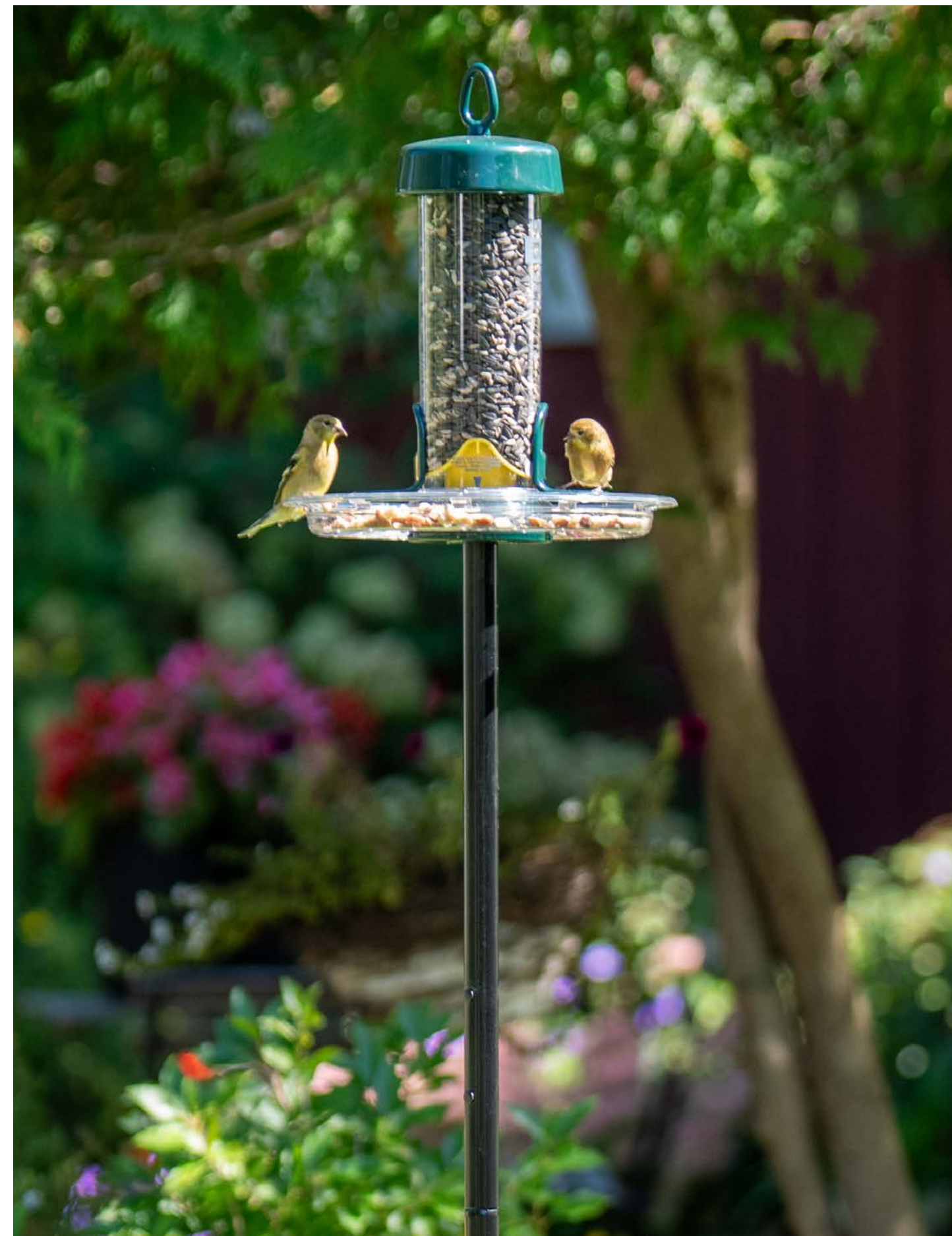

Tube Solution™ 150 Podium™

1268

Included

- Single Pole Kit model #1108-V01
- Seed Tray model #3003-V01
- Tube Solution™ 150 Feeder model #1116-V01



SEE VIDEO

**THE ULTIMATE BIRD
FEEDING STATION!**

Model #1268-V01	Product & Box
Qty	1
Product Materials	Metal & Plastic
Capacity	1.5 quarts/2.6 lbs
Dimensions (W x L x H)	24" x 11.5" x 8.5"
Weight	9 lbs.
UPC	628209126811

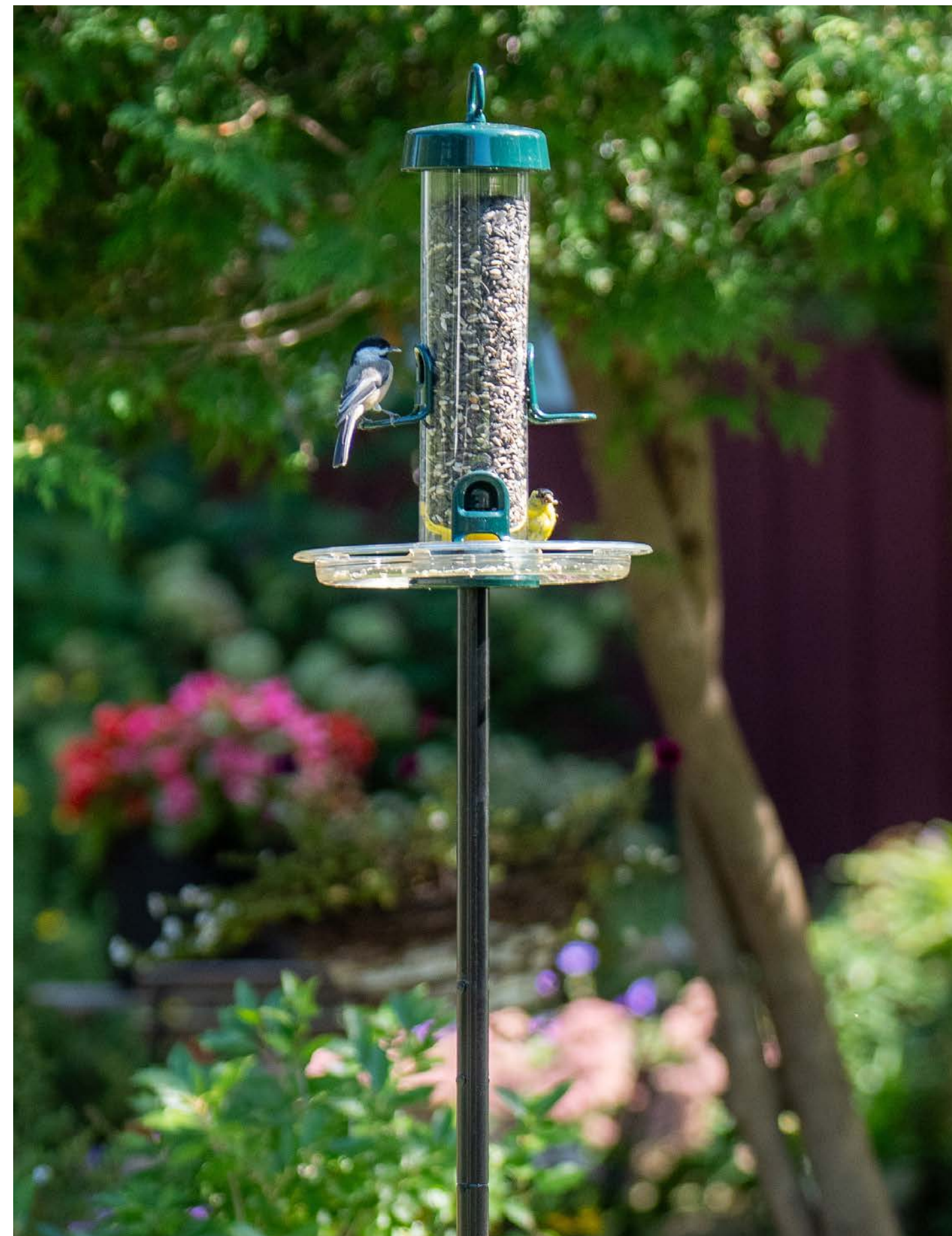

Tube Solution™ 200 Podium™

1269

Included

- Single Pole Kit model #1108-V01
- Seed Buster™ Tray model #1020-V01
- Seed Tray model #3003-V01
- Tube Solution™ 200 Feeder model #1117-V01



SEE VIDEO

**THE ULTIMATE BIRD
FEEDING STATION!**

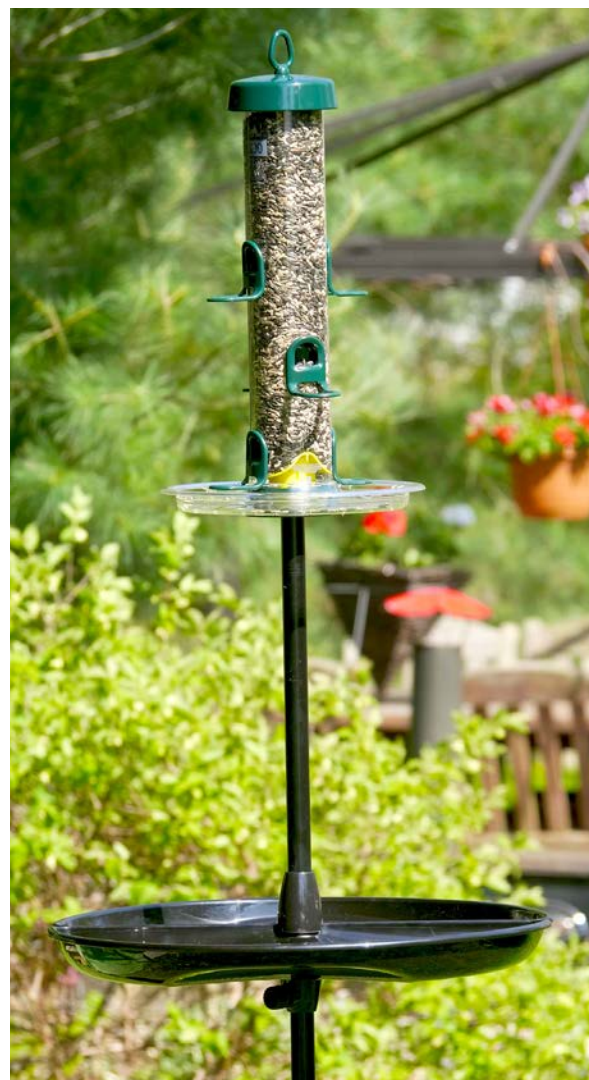

Model #1269-V01	Product & Box
Qty	1
Product Materials	Metal, Plastic & Resin
Capacity	2 quarts/3.4 lbs
Dimensions (W x L x H)	24" x 20" x 7"
Weight	12.5 lbs.
UPC	628209126910



DETACHABLE
COMPONENT SYSTEM™



CHEW PROOF



SEED TUBE VENTILATION™



UV RESISTANT



LIFETIME CARE™

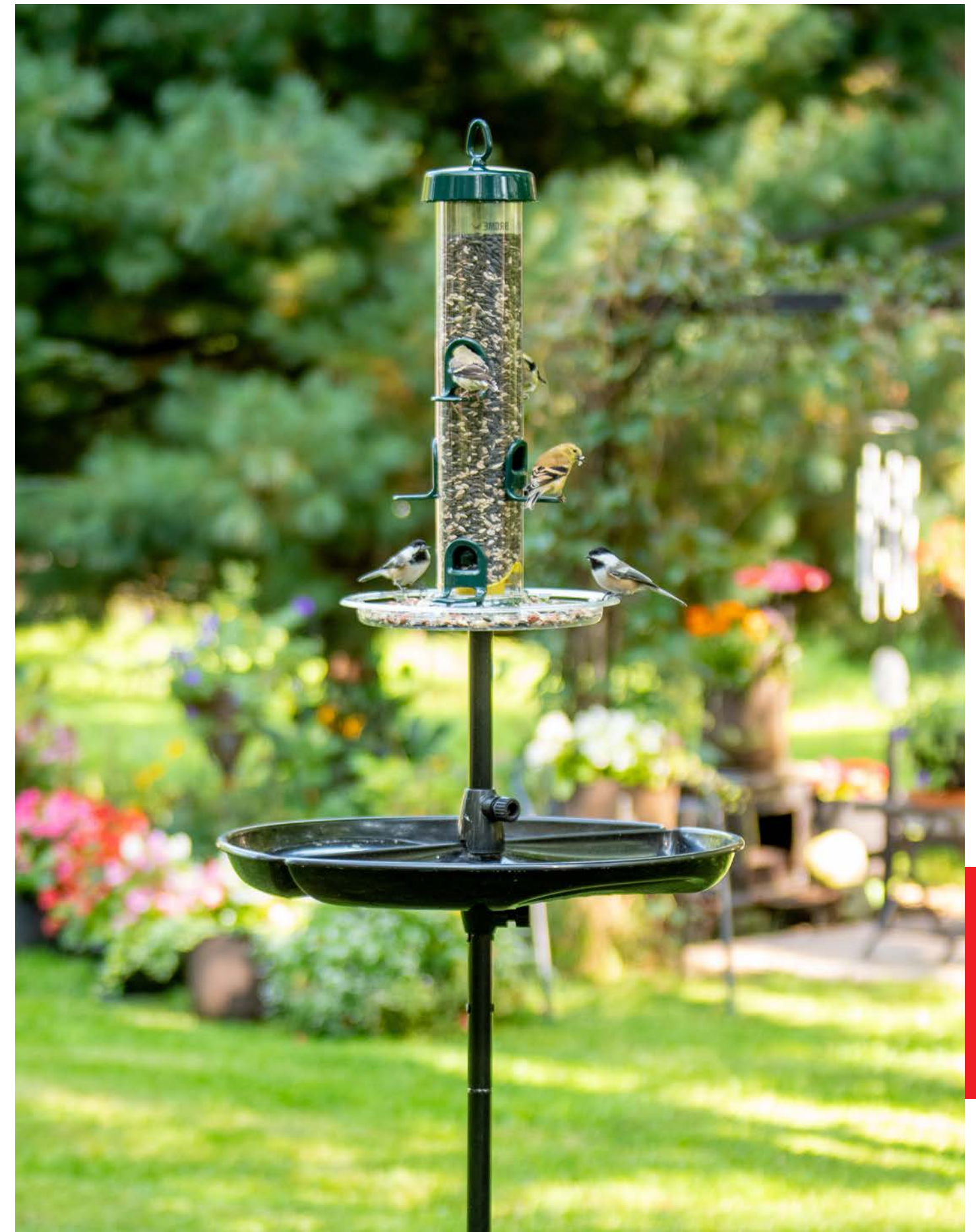



SEE VIDEO

BirdsUP™

25" HANGING BRACKET

Model #1258-V01	Product & Box	Master Carton
Qty	1	4
Product Materials	Metal	N/A
Capacity	25 lbs	N/A
Dimensions (W x L x H)	25.4" x 4.8" x 2.5"	26" x 5.1" x 10.3"
Weight	2 lbs.	9 lbs.
UPC	628209125814	10628209125811

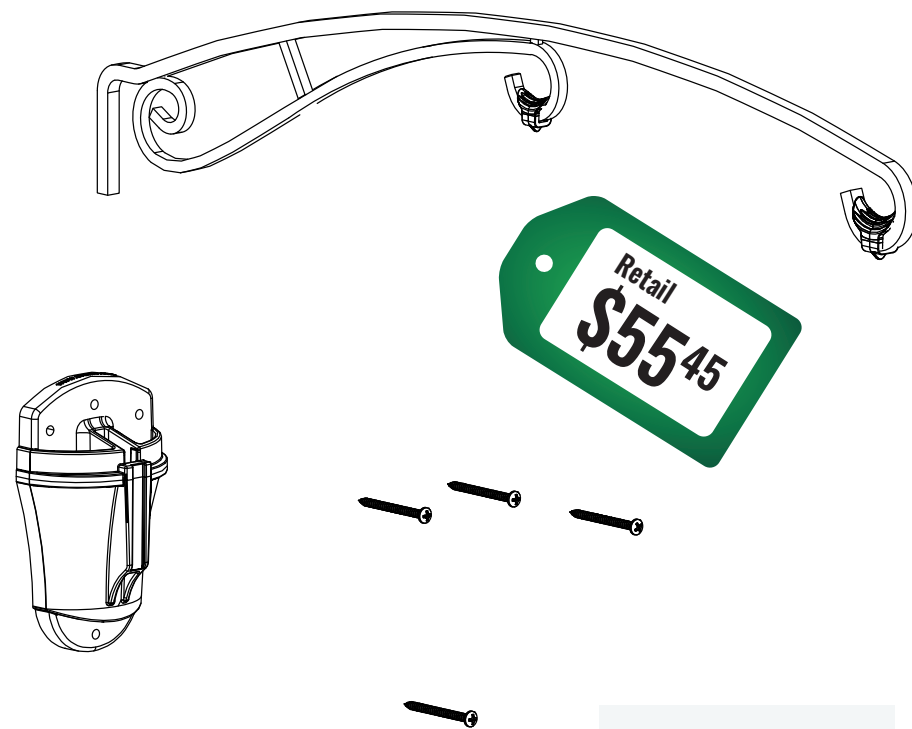

Included:

- 1 25" long arm
- 1 Docking hub
- 4 Stainless steel screws



STAINLESS STEEL SNAP HOOK

Model #1257-V01	Product & Header	Master Carton	Shipper
Qty	1	12	144
Product Materials	Stainless Steel	N/A	N/A
Capacity	N/A	N/A	N/A
Dimensions (W x L x H)	6.5" x 4" x 0.5"	5.8" x 4.3" x 3.7"	15.7" x 13.6" x 6.7"
Weight	0.1 lbs.	1.6 lbs.	23 lbs.
UPC	628209125715	10628209125712	20628209125719



1-INCH MOUNTING FLANGE

Model #1244-V01	Product & Header	Master Carton	Shipper
Qty	1	6	150
Product Materials	ASA Plastic	N/A	N/A
Capacity	N/A	N/A	N/A
Dimensions (W x L x H)	7.5" x 4.75" x 2"	9.5" x 4" x 2.8"	21.5" x 14.9" x 10.2"
Weight	0.1 lbs.	0.9 lbs.	23 lbs.
UPC	628209124411	10628209124418	20628209124415



BirdsUP™

PATIO BASE

Model #1168-V01	Product & Box	Master Carton
Qty	1	*
Product Materials	Metal	*
Capacity	*	*
Dimensions (W x L x H)	*	*
Weight	*	*
UPC	628209116812	10628209116819

* Available Fall 2024

Retail
\$116.45

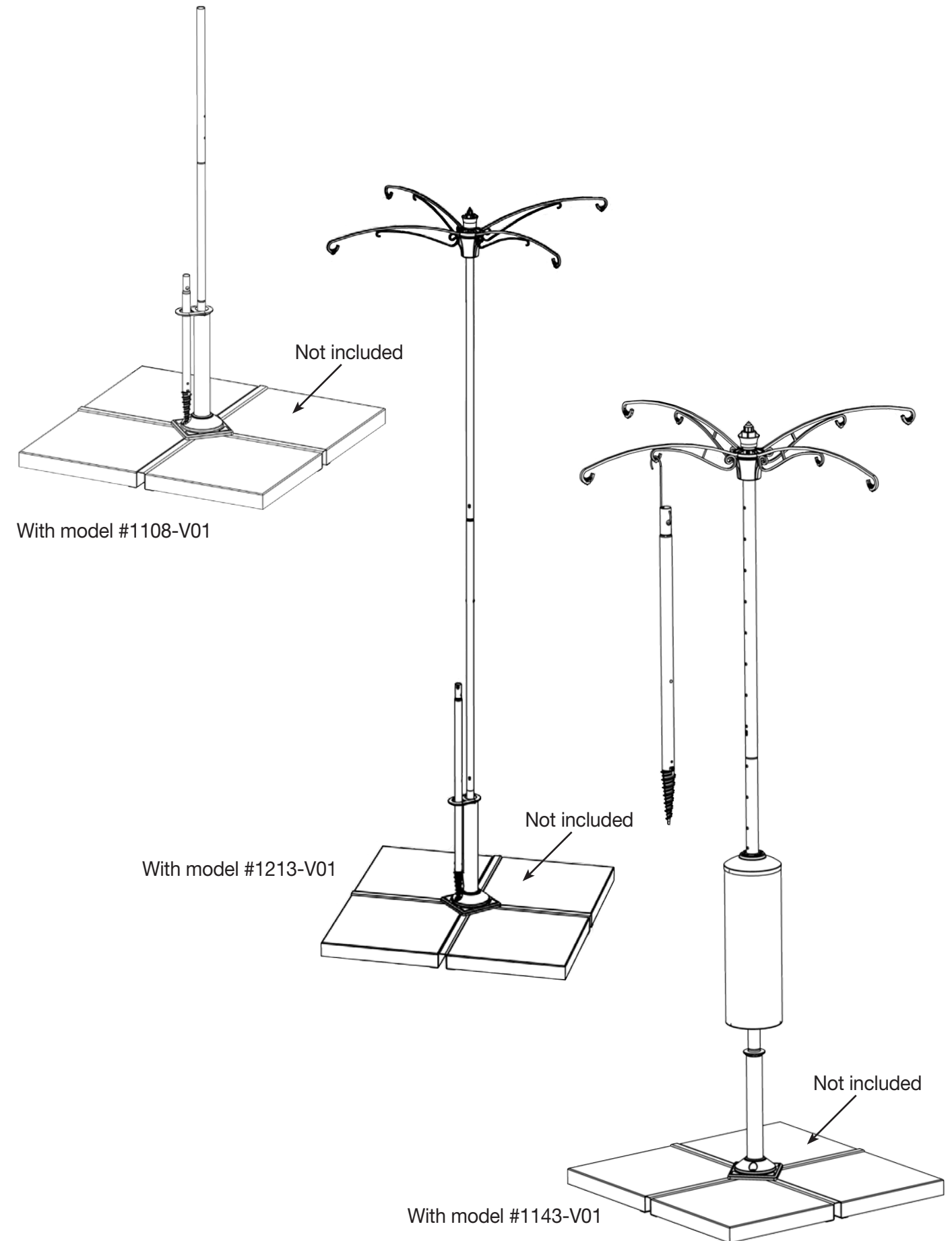
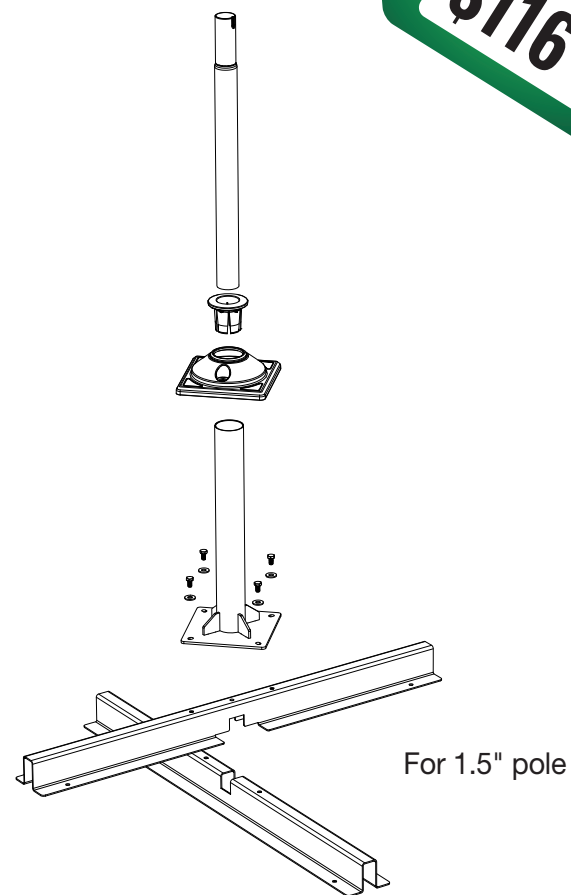
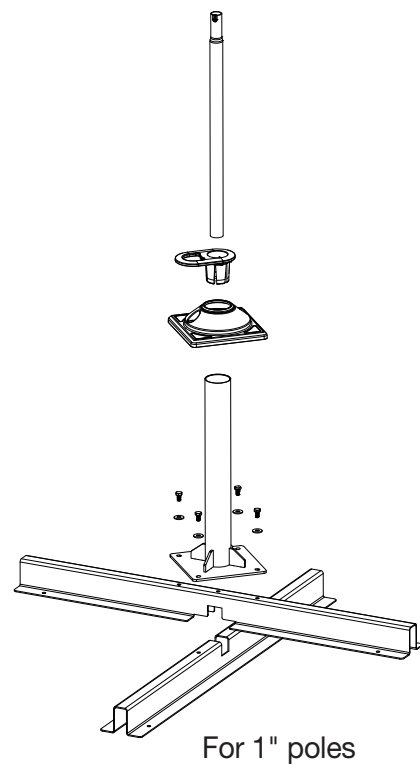

S-HOOK AND BRANCH HOOK

Model # & Description	UPC code	Price
Model #1202 Stainless S-Hook 1.6"×1.6"×6"	628209120215	\$ 2.95
Model #1203 Stainless S-Hook 1.6"×1.6"×8"	628209120314	\$ 3.45
Model #1204 Stainless S-Hook 1.6"×1.6"×12"	628209120413	\$ 3.95
Model #1205 Stainless S-Hook 1.6"×1.6"×15"	628209120512	\$ 4.45
MODEL #1206 Stainless Branch Hook 1.6"×5"×8"	628209120611	\$ 3.95
Model #1207 Stainless Branch Hook 1.6"×5"×12"	628209120710	\$ 4.45
Model #1208 Stainless S-Hook 1.6"×1.6"×18"	628209120819	\$ 4.95
Model #1209 Stainless Branch Hook 1.6"×5"×24"	628209120918	\$ 5.45

S-Hook

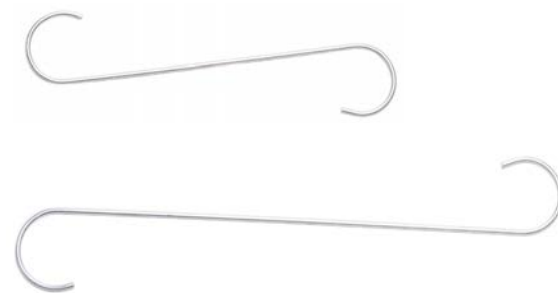

Branch Hook

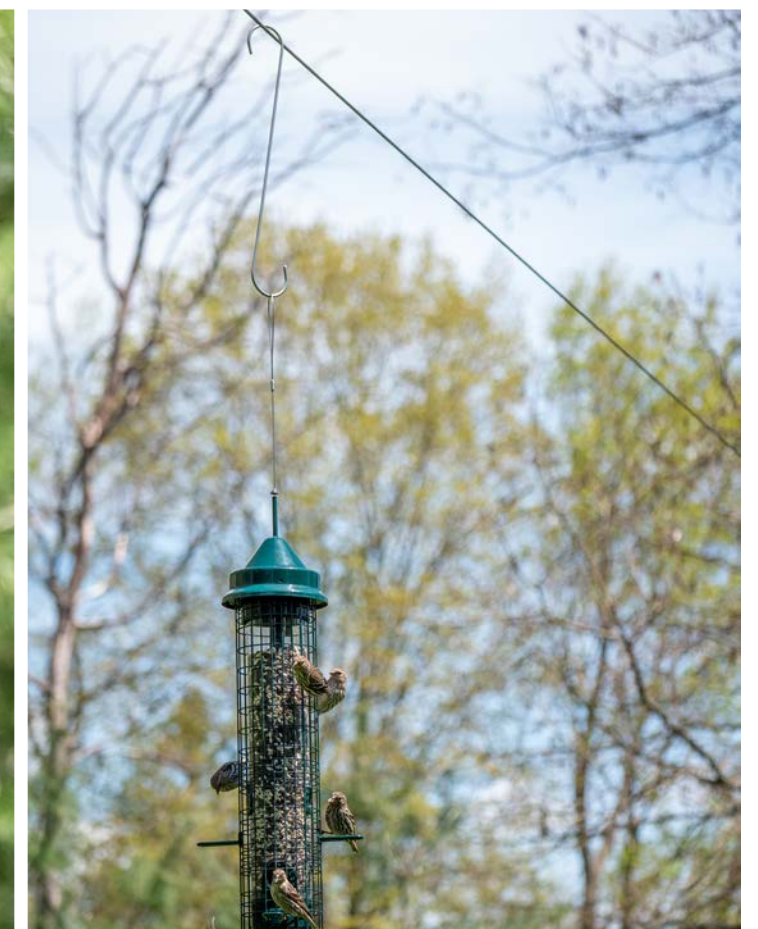

Truly Squirrel-proof™

Supported by an impressive list of patents, our feeders are recognized as the leaders in the squirrel proof category. The weight of an adult squirrel automatically closes the seed ports, denying access to the seed but not harming the squirrels in any way. Also effective for some large nuisance birds.

**We are truly squirrel-proof
not squirrel-resistant.**



Chew Proof

All feeder parts exposed to squirrels are made of chew proof metals or RoxResin®, a remarkable 100% chew proof, waterproof, rust proof and UV resistant material.



Detachable Component System™

Squirrel Buster® bird feeders are designed to be dismantled by hand into individual components without the use of tools. This allows for easy cleaning and maintenance.



Seed Tube Ventilation™

Transparent seed tubes trap solar energy. Conventional seed tube designs block the escape of the heated air. Our patented Seed Tube Ventilation™ permits humidity and hot air to escape through vents at the top of the feeder and replaces it with fresh air. Bird food remains fresher, attracting more wild birds.



Weight Adjustable for Selective Feeding

The patented adjustable spring mechanism controls how much weight the shroud will support, allowing birds to feed. Any additional weight will activate the closing mechanism deterring heavier birds.



UV Resistant

All components are UV resistant.



Our Visions and Responsibilities

We do our best to make sure that our products remain true to our commitment from the concept stage to hanging in your garden. We are continuously monitoring our materials to ensure that they are environmentally friendly and compliant. We promote fair labor practices and safe working conditions throughout our supply chain with international code of conduct audits. We are members in good standing of AMFORI, the leading global business association for open and sustainable trade, whose objectives contribute to the fulfillment of the UN Sustainable Development Goals. Our core values are: Caring, Honesty, Respect, Responsibility and Fairness. Our founding principle is that our business can do well, when you and the planet do well.

Should you need a part covered under our warranty, we will provide it for free to extend the life of our products, and shipping is on us.

Call us for advice or help.
A real person will be happy to assist:

1-800-856-5685

BROME[®] 

331 ch. Knowlton Rd
Knowlton QC JOE 1V0
Canada

1-800-856-5685



www.brome.com